

Transcutaneous monitoring – understanding the principles

Transcutaneous monitoring has been used for thirty years to assess the oxygen and carbon dioxide status of babies in the NICU nursery, yet the significance of transcutaneous monitor readings is often misunderstood. This article examines the technique's underlying physical and physiological principles.

Ian Bromley

BSc MSc CSci MIPEM
Clinical Scientist
UCL Hospitals Neonatal Unit
EGA Hospital, London
ian.bromley@uclh.nhs.uk

Keywords

transcutaneous monitoring; HFOV; neonatal blood gases; oxygen monitoring; carbon dioxide monitoring

Key points

Bromley I. Transcutaneous monitoring – understanding the principles. *Infant* 2008; 4(3): 95-98.

1. Transcutaneous blood gas values are physiologically significant entities in their own right.
2. They provide useful clinical information, even if they are not the same as the underlying arterial blood gas values.
3. When used correctly, transcutaneous monitoring should not cause 'skin burns'.
4. Transcutaneous pO₂ provides trend information on the oxygen supply to the skin, and is influenced by the peripheral circulation.
5. Transcutaneous pCO₂ is especially important with HFOV, where it can provide early warning of hypocapnia.

One of the primary goals of the care of sick neonates is to ensure adequate oxygen supply to the baby's tissues and vital organs. Hypoxia is as dangerous to neonates as it is to any other patient group, although neonates may be more resistant to hypoxia. Hyperoxia, however, is especially dangerous for neonates. It has been known for over 50 years that preterm babies are at risk of blindness, and hyperoxia (arterial pO₂ that is too high) has often been implicated in this condition.

The blood gas analyser measurement of an arterial blood gas (ABG) sample has long been established as the 'gold standard' for monitoring the adequacy of oxygenation and ventilation. The direct reporting by the blood gas analyser of gas partial pressures (the 'p' in pO₂ and pCO₂) is of fundamental physiological importance, since partial pressure differences across cell membranes are the 'driving forces' governing the rate of gas diffusion across those membranes.

It is generally accepted that the arterial pCO₂ has a marked effect on the cerebral circulation: decreasing pCO₂ results in reduced cerebral blood flow. There is increasing evidence that low pCO₂ may be associated with adverse cerebral outcome^{1,2}. The lower the pCO₂, the shorter the time required for brain damage to occur.

Continuous assessment of pCO₂ is especially important during high frequency oscillatory ventilation (HFOV). The oscillator is a powerful machine that can quickly drive pCO₂ to unsafe levels.

History of transcutaneous monitoring

In the 1970s the increasing use of mechanical ventilation in the NICU led to

the finding that ABG values could show marked variation which was not picked up by intermittent blood sample analysis. The appearance of commercial transcutaneous pO₂ monitors in 1977, and transcutaneous pCO₂ monitors in 1978, represented a timely fusion of physiological understanding and technical innovation.

Pioneering experimental physiologists discovered over 150 years ago that human skin 'breathes' – that is it takes up oxygen³ and gives off carbon dioxide⁴ to the surrounding air. If skin is covered by a flat, unheated pO₂ electrode, the surface pO₂ falls to zero in a few minutes. However, if skin blood flow is greatly increased by locally heating the skin to the highest tolerable temperature (45°C) the surface pO₂ rises to approximate the arterial pO₂⁵.

Carbon dioxide diffuses through the skin surface much more readily than oxygen: a transcutaneous sensor heated to only 37°C would give an accurate representation of the arterial pCO₂, but the response time (the time taken to react to a sudden change in pCO₂) would be unacceptably long.

The Clark pO₂ electrode and Severinghaus pCO₂ electrode (still the basis of modern blood gas analyser electrodes) were incorporated into membrane-covered devices suitable for application to neonates. At first, the machines were cumbersome, requiring separate monitors and sensors for transcutaneous pO₂ and pCO₂. The first 'combined' transcutaneous pO₂ and pCO₂ monitoring system was described in 1979⁶, and was the forerunner of today's transcutaneous monitors.

The transcutaneous sensor

It is helpful to understand how the transcutaneous sensor works, if only to

realise how conceptually simple the device is, and hence susceptible to mis-interpretation of the readings.

FIGURE 1 shows a cross-section of the Radiometer E5280 combined O_2/CO_2 transcutaneous sensor, which is the model most widely used. Although the transcutaneous sensor is hard to manufacture (and hence relatively expensive: approximately £1,900), its operating principle is straightforward.

The core of the sensor is a silver cylinder, into which is embedded a heating element and temperature sensors. Through the silver ring passes a fine platinum wire, which forms part of the pO_2 sensor. Also at the surface of the silver is a solid state pH sensor. A thin electrolyte layer is held in place over the slightly convex silver cylinder by tightly stretched membranes (held in place by O-rings). The membrane material is permeable to O_2 and CO_2 , but not much else. Oxygen and CO_2 outside the sensor diffuse across the membrane into the electrolyte. A tiny current is generated which is proportional to the pO_2 the sensor is exposed to, and CO_2 diffusing into the electrolyte changes its pH depending on the pCO_2 to which the sensor is exposed.

All the transcutaneous sensor measures is the pO_2 and pCO_2 at the membrane surface: it can't distinguish whether these gases come from room air, calibration gas, or O_2 and CO_2 induced to move to the skin surface by heating the transcutaneous sensor.

Over time, the sensor changes its sensitivity, so frequent calibration is required. This is done by exposing the sensor to a calibration gas mixture whose CO_2 and O_2 composition is accurately known. The sensor is 17 mm in diameter. Although relatively robust, a large number of fine wires pass through the cable and attach to the sensor head, so careful handling is advised. If any of these connections break, the sensor is impossible to repair.

Transcutaneous sensor on the skin

That transcutaneous monitoring works at all depends on the unusual superficial skin structure. Although the epidermis (outer layer) is essentially avascular, the lower dermal layers are bathed with tissue fluid. Capillary loops extend from the subcutaneous tissue through these layers to within a short distance of the skin surface (0.3 mm in the case of very low birth-

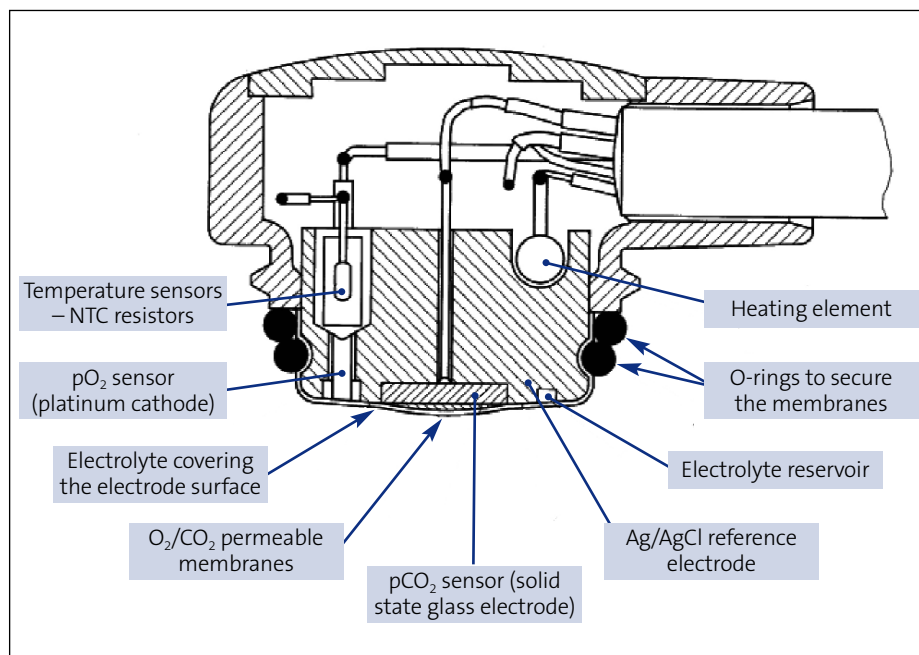

FIGURE 1 Diagram showing a cross section of the Radiometer E5280 transcutaneous sensor. Image courtesy of Radiometer Medical.

weight infants). This structure forms part of the body's temperature regulation system. In response to increasing temperature, these capillary loops dilate, producing an increased flow of blood to the skin surface. This allows the blood to cool.

The heat from the transcutaneous sensor causes vasodilatation of the capillary loops, producing a massive increase in local skin blood flow. This causes the blood near the sensor site to be 'arterialised'. Increasing the temperature of the in-rushing blood causes a rightward shift of the oxyhaemoglobin dissociation curve, effectively increasing its pO_2 . However, the higher temperature causes increased tissue metabolism: more O_2 is mopped up in the highly metabolically active dermal layer, so less gets through to the surface. At about $43^\circ C$, there is a critical balance of these (and other) temperature effects. Provided this critical balance is not upset, the transcutaneous pO_2 ($tcpO_2$) at the skin surface agrees closely with the arterial pO_2 .

The calibrated sensor is attached to the baby's skin by special sticky fixation rings. Some contact gel is placed in the well of the fixation ring before the sensor is secured. This is designed to exclude stray air, stopping it from reaching the sensor, and to provide good thermal contact with the skin. Care must be taken when applying the sensor to the skin surface to exclude air bubbles, which would produce

spurious high pO_2 readings. Once the sensor has been applied, it takes about 10-15 minutes for 'hyperaemisation' to take place: only then, are the transcutaneous readings meaningful.

Is transcutaneous monitoring accurate?

More than most techniques encountered in the NICU nursery, transcutaneous monitoring requires a high level of understanding and interpretation. Provided the system has been correctly calibrated, and the transcutaneous sensor has been properly applied to the baby's skin, the monitor readings should accurately reflect the transcutaneous gas values at the sensor site.

The transcutaneous values are of intrinsic value, as physiological entities in their own right, and are of greater value than the extent to which they reflect underlying ABG values. Given that all we have done is to attach a small heated sensor to the skin, one could argue that transcutaneous values agree with ABG more often than we have any right to expect.

The transcutaneous values aren't necessarily 'inaccurate' in cases of poor agreement: they are just different. The expectation, even in NICUs with considerable experience in transcutaneous monitoring, is that the transcutaneous values should agree with ABG results: if

they don't agree, "something must be wrong with the machine". The usual course of action is to 're-membrane' the transcutaneous sensor, often unnecessarily. The principal beneficiary is the manufacturer, who sells more transcutaneous consumables!

Here are a few of the mechanisms which could lead to discrepancy:

Transcutaneous pO₂

Transcutaneous pO₂ provides trend information on the oxygen supply to the skin. In an haemodynamically unstable baby, the transcutaneous pO₂ reflects changes in the circulatory status. The transcutaneous pO₂ is influenced not only by the arterial pO₂, but also by the peripheral circulation. For example, if the baby is cold, or in shock, the resultant lowering of peripheral blood flow would cause tcpO₂ to markedly under-read the arterial pO₂.

Similarly, if the baby is lying on the transcutaneous sensor, local skin blood flow is greatly diminished (as well as it being extremely uncomfortable for the baby).

If the baby is shunting, for example in the case of patent ductus arteriosus, it is important to recognise whether the ABG sample used for comparison with the transcutaneous monitor represents the same circulatory pathway (pre- or post-ductal) as the transcutaneous sensor.

Part of the skill that comes with experience of transcutaneous monitoring is the ability to recognise when the transcutaneous values are likely to be different from ABG: interpretation of the transcutaneous readings is required.

Transcutaneous pCO₂

The tcpCO₂ sensor would read correctly when heated to only 37°C, but since the tcpO₂ side of the transcutaneous sensor requires the skin surface to be heated to 43°C in order to function correctly, the tcpCO₂ measurement is also taken at 43°C (combined sensor). This increased temperature offers the advantage of improved response time (i.e. the system reacts much more quickly to a sudden change in the pCO₂). However, the production of CO₂ is greatly increased at this higher temperature due to increased tissue metabolism. This effect can be cancelled out by applying a 'correction factor': this 'adjusts' the calibration values

to give a reading approximately 30% less than the expected value in the calibration gas. This correction factor should always be switched "on" (often indicated by "corr" on the monitor display). If it isn't, reported tcpCO₂ values will over-read by about 30%.

A rising transcutaneous pCO₂ should always be considered clinically significant until proved otherwise: it may indicate decreasing peripheral perfusion. It can also alert staff to a pneumothorax before other clinical signs⁷.

"It's not working!"

Even in NICUs where transcutaneous monitoring is well established, one frequently hears the refrain "it's not working properly". This usually means either the system has failed to calibrate, or it's not accurate, meaning the transcutaneous values don't agree with the latest blood gas analyser results.

Calibration problems can usually be corrected by changing the sensor membrane (or checking the gas line connecting the calibrator to the sensor port has not been accidentally disconnected), although it is possible the sensor has failed. When used intensively the sensor has an average lifetime of approximately two years.

Reported 'inaccuracy' often arises from misplaced expectations of the technique, rather than technical failure. Provided the sensor has been correctly calibrated and carefully applied, the system should accurately reflect the transcutaneous gas values at the sensor site, although these may be different from ABG values.

Disadvantages of transcutaneous monitoring

Transcutaneous monitoring is undoubtedly more complicated to use than other techniques. The sensor has to be re-sited regularly (at least four-hourly) to minimise risk of skin damage.

Erythema (slight reddening of the skin at sensor sites) can occur, but quickly fades once monitoring has stopped. There is a common misconception that transcutaneous monitoring inevitably leads to skin burns. It must be admitted that over 20 years ago, it was common to see slight burn marks persisting to examination at follow-up clinics, but these marks are no longer seen. This may in part be attributed to a trend towards lower transcutaneous temperatures: 43°C is now widely used,

compared with 44°C in the early years of transcutaneous monitoring.

If the baby's skin is especially fragile, it is recommended that the exposure time is reduced (from four to two hours or less) per site rather than reducing the temperature.

The system has to be calibrated regularly (for convenience, at the same time as re-siting) to maintain accuracy. If the sensor won't calibrate, or the sensor's membrane is damaged, a 're-membraning' procedure must be carried out.

What do you need to get started with transcutaneous monitoring?

Many manufacturers offer transcutaneous 'modules' for their monitoring systems. Transcutaneous values are displayed on the standard monitoring screen. Transcutaneous sensors and calibrators can be purchased either from the monitor manufacturer, or directly from Radiometer.

Alternatively, Radiometer manufactures a 'stand-alone' transcutaneous monitor (the TCM40), which neatly accommodates the calibration gas cylinder within the monitor case.

More important than the equipment, is the commitment of the NICU nursing staff to transcutaneous monitoring. If they don't recognise the potential benefit to the babies in their care, the investment in transcutaneous monitoring is likely to remain unused in store rooms gathering dust.

Conclusion

Since the mid 1980s, many NICUs which had been established transcutaneous users, shifted away from transcutaneous pO₂ to pulse oximetry. This may have been because pulse oximeters are much simpler to use.

What is often overlooked is the potential danger of using saturation readings from a pulse oximeter to prevent hyperoxia: the stated accuracy of \pm or -3 digits⁸ – or worse, can take you a long way along the pO₂ axis of the oxyhaemoglobin dissociation curve. This is especially problematic when the 'shifting' of the curve itself in response to changing physiological parameters is taken into account.

Due care has to be taken when attaching saturation probes to ensure they are not applied too tightly, or left in one place on the baby's skin for too long⁹.



FIGURE 2 The 'Tiny Teddy' transcutaneous monitoring sensor. Photograph courtesy of Radiometer Medical.

Unfortunately, this move away from transcutaneous monitoring has left many NICUs without reliable continuous monitoring of $p\text{CO}_2$. This is especially of concern where HFOV is used.

A new product, the Radiometer "Tiny Teddy" – about to be launched in the UK,

should go some way to meeting the concerns of nursing staff about the complexity of transcutaneous monitoring in the NICU setting (FIGURE 2). The sensor is smaller and simpler to maintain than its predecessor, and should be easier to apply to VLBW infants.

Transcutaneous monitoring is unfortunately not a cheap option: consumables (calibration gas cylinders, membrane kits, and fixation kits) must all be purchased.

It is difficult for nursing staff to manage sick infants when presented with a constellation of apparently conflicting information about the baby's blood gas status from different machines. However, in spite of its limitations, transcutaneous monitoring¹⁰ still has a place in the NICU nursery.

References

1. **Graziani U., Spitzer A.R., Mitchell D.G., Merton D.A. et al.** Mechanical ventilation in preterm infants. Neurosonographic and developmental studies. *Pediatrics* 1992; **90**: 515-22.
2. **Greisen G., Vannucci R.C.** Is periventricular leucomalacia a result of hypoxic-ischaemic injury? Hypocapnia and the preterm brain. *Biol Neonate* 2001; **79**(3-4): 194-200.
3. **Von Gerlach.** Über das Hautathmen. *Arch Anat Physiol (Leipzig)* 1851; 431-39.
4. **Abernathy J.** An essay on the nature of the matter perspired and absorbed from the skin. *Surgical and Physiological Essays Part II.* London 1793; 107-65.
5. **Baumburger J.P., Goodfriend R.B.** Determination of arterial oxygen tension in man by equilibration through intact skin. *Fede Proc* 1951; **10**: 10-21.
6. **Parker D., Delpy D., Reynolds E.O.R.** Single electrochemical sensor for transcutaneous measurement of $p\text{O}_2$ and $p\text{CO}_2$. *Birth Defects: Original Article Series* 1979; **15**: 109-16.
7. **McIntosh N., Becher J.C., Cunningham S et al.** Clinical diagnosis of pneumothorax is late: use of trend data and decision support might allow preclinical detection. *Pediatr Res* 2000; **48**(3): 408-15.
8. **Masimo Radical 7 Specifications:** Masimo Corporation 2007.
9. **Wright I.M.R., Puntis J.W.L.** A case of skin necrosis related to a pulse oximeter probe. *Br J Intensive Care* 1993; 394-98.
10. **Lundstrom K.** Continuous Blood Gas Monitoring in Neonates and Infants: Radiometer Medical ApS Denmark 2005.

BAPM Perinatal Trainees Meeting

18 November 2008

Royal Institute of British Architects, 66 Portland Place, London W1

This day is suitable for all those undergoing training (or those considering training) in either obstetrics or neonatology. Delegates may book individual surgeries during lunchtime for advice on career pathways and/or information on specific training requirements.

Programme includes talks on National Standards for Perinatal Care, Parental Involvement in Perinatal Care, the Management of NEC and a career guidance session including the National Grid process.

Further details available from:

British Association of Perinatal Medicine
5-11 Theobalds Road, London WC1X 8SH
Tel: 020 7092 6085
Fax: 020 7092 6001
Email: bapm@rcpch.ac.uk



PERINATAL MEDICINE 2008

A joint meeting of the British Maternal and Fetal Medicine Society, British Association of Perinatal Medicine, Neonatal Society and the Neonatal Nurses Association



2nd - 4th JUNE 2008

Harrogate International Centre
HARROGATE, UK

KEYNOTE LECTURES INCLUDE:

- **Placental insufficiency - will it be preventable by 2010?**
Professor John Kingdom (Toronto, Canada)
- **Lung surfactant: protecting alveolar stability and sterility**
Professor Sam Hawgood (San Francisco, USA)
- **Neuroprotection after hypothermia**
Professor Pierre Gressens (Paris, France)
- **Pathways to fetal inflammation, preterm birth and injury**
Professor John Newnham (Perth, Australia)
- **Perinatal inflammation and central nervous system injury**
Professor Olaf Dammann (Hanover, Germany)

PROGRAMME HIGHLIGHTS INCLUDE:

- **FETAL GROWTH RESTRICTION**
Is catch up growth good for you?
Neurocognitive outcomes
- **PERINATAL INFLAMMATION**
Inflammation and disability
- **DEBATE - BORDERLINE VIABILITY**
Has patient choice gone too far?
- **OUTCOMES**
Perinatal psychiatry
Developmental care
Skin to skin contact
Positive parenting
Feeding difficulties
Surgical interventions
- **SOCIETY LECTURES**
- **PARALLEL SESSIONS**
- **FREE COMMUNICATIONS**
- **SCIENTIFIC POSTER DISPLAYS**

For further information, please contact the Conference Secretariat:

Hampton Medical Conferences Ltd.
113-119 High Street, Hampton Hill, Middlesex, TW12 1NJ, UK
Tel: +44 (0) 20 8979 8300 Fax: +44 (0) 20 8979 6700
Email: fetal@hamptonmedical.com
Web: www.perinatalmedicine2008.ukevents.org

www.perinatalmedicine2008.ukevents.org